

Cambia

11 月 19 日

2018

---

Allen Bradley Chassis Datasheet

## 1756 ControlLogix Chassis Specifications

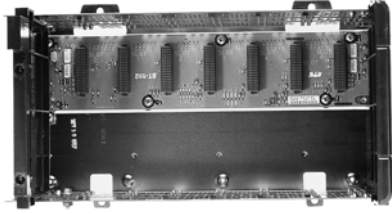

**Standard Catalog Numbers** 1756-A4, 1756-A7, 1756-A10, 1756-A13, 1756-A17

**ControlLogix-XT Catalog Numbers** 1756-A5XT, 1756-A7LXT

Topic	Page
1756 Standard Chassis	2
1756 ControlLogix-XT Chassis	4
1756 Chassis Accessories	5
Spacing Requirements	6
Standard Mounting Dimensions	7

The ControlLogix system is a modular system that requires a 1756 I/O chassis. All of the chassis are designed for horizontal-only, back-panel mounting. Place any module into any slot. The backplane provides a high-speed communication path between modules.

AutoCAD product drawings are available at <http://www.rockwellautomation.com/en/e-tools/drawings.html>

## 1756 Standard Chassis

The chassis backplane provides a high-speed communication path between modules and distributes power to each of the modules within the chassis.

### Environmental Specifications - 1756 Standard Chassis

Attribute	1756-A4, 1756-A7, 1756-A10, 1756-A13, 1756-A17
Temperature, operating IEC 60068-2-1 (Test Ad, Operating Cold), IEC 60068-2-2 (Test Bd, Operating Dry Heat), IEC 60068-2-14 (Test Nb, Operating Thermal Shock)	0...60 °C (32...140 °F)
Temperature, storage IEC 60068-2-1 (Test Ab, Unpackaged Nonoperating Cold), IEC 60068-2-2 (Test Bb, Unpackaged Nonoperating Dry Heat), IEC 60068-2-14 (Test Na, Unpackaged Nonoperating Thermal Shock)	-40...85 °C (-40...185 °F)
Relative humidity IEC 60068-2-30 (Test Db, Unpackaged Nonoperating Damp Heat)	5...95% noncondensing
Vibration IEC 60068-2-6 (Test Fc, Operating)	2 g @ 10...500 Hz
Shock, operating IEC 60068-2-27 (Test Ea, Unpackaged Shock)	30 g
Shock, nonoperating IEC 60068-2-27 (Test Ea, Unpackaged Shock)	50 g

### Technical Specifications - 1756 Standard Chassis

Attribute	1756-A4	1756-A7	1756-A10	1756-A13	1756-A17
Backplane current, chassis/slot max @ 1.2V DC	1.5 A/1.5 A				
Backplane current, chassis/slot max @ 3.3V DC	4 A/4 A				
Backplane current, chassis/slot max @ 5.1V DC	15 A/6 A				
Backplane current, chassis/slot max @ 24V DC	2.8 A/2.8 A				
Power dissipation	6.1 BTU/hr				
Power consumption	1.8 W				
Slots	4	7	10	13	17
Mounting method	Horizontal only				
Dimensions (WxHxD), approx. <sup>(1)</sup>	263 x 169 x 145 mm (10.35 x 6.65 x 5.71 in.)	368 x 169 x 145 mm (14.49 x 6.65 x 5.71 in.)	483 x 169 x 145 mm (19.0 x 6.65 x 5.71 in.)	588 x 169 x 145 mm (23.15 x 6.65 x 5.71 in.)	738 x 169 x 145 mm (29.06 x 6.65 x 5.71 in.)
Cabinet size (WxHxD), min	507 x 507 x 203 mm (20 x 20 x 8 in.)	507 x 609 x 203 mm (20 x 24 x 8 in.)	762 x 507 x 203 mm (30 x 20 x 8 in.)	762 x 609 x 203 mm (30 x 24 x 8 in.)	914 x 762 x 203 mm (36 x 30 x 8 in.)
Weight, approx.	0.75 kg (1.7 lb)	1.10 kg (2.4 lb)	1.45 kg (3.2 lb)	1.90 kg (4.2 lb)	2.20 kg (4.8 lb)
Location	Panel				
North American temperature code	T5				
IEC temperature code	T6				
Enclosure type rating	None (open-style)				

<sup>(1)</sup> Dimensions include mounting tabs and power supply. Depth with extended terminal housing (1756-TBE) is 160 mm (6.3 in.).

## Certifications - 1756 Standard Chassis

Certification <sup>(1)</sup>	<b>1756-A4, 1756-A7, 1756-A10, 1756-A13, 1756-A17</b>
c-UL-us	UL Listed Industrial Control Equipment, certified for US and Canada. See UL File E65584.  UL Listed for Class I, Division 2 Group A,B,C,D Hazardous Locations, certified for U.S. and Canada. See UL File E194810.
CSA	CSA Certified Process Control Equipment. See CSA File LR54689C.  CSA Certified Process Control Equipment for Class I, Division 2 Group A,B,C,D Hazardous Locations. See CSA File LR69960C.
ATEX	European Union 94/9/EC ATEX Directive, compliant with: EN 60079-15; Potentially Explosive Atmospheres, Protection "n" (Zone 2)
CE	European Union 2004/108/IEC EMC Directive, compliant with: <ul style="list-style-type: none"> <li>• EN 61326-1; Meas./Control/Lab., Industrial Requirements</li> <li>• EN 61000-6-2; Industrial Immunity</li> <li>• EN 61000-6-4; Industrial Emissions</li> <li>• EN 61131-2; Programmable Controllers (Clause 8, Zone A &amp; B)</li> </ul>
C-Tick	Australian Radiocommunications Act, compliant with: AS/NZS CISPR 11; Industrial Emissions
FM	FM Approved Equipment for use in Class I Division 2 Group A,B,C,D Hazardous Locations
TÜV	TÜV Certified for Functional Safety: up to and including SIL 2

<sup>(1)</sup> When marked. See the Product Certification link at <http://www.ab.com> for Declarations of Conformity, Certificates, and other certification details.

## 1756 ControlLogix-XT Chassis

The ControlLogix-XT products include control and communication system components that, when used with FLEX I/O-XT products, provide a complete control system solution that can be used in environments where temperatures range from -20...70 °C (-4...158 °F).

When used independently, the ControlLogix-XT system can withstand environments where the temperature ranges from -25...70 °C (-13...158 °F).

### Environmental Specifications - 1756 ControlLogix-XT Chassis

Attribute	1756-A5XT, 1756-A7LXT
Temperature, operating IEC 60068-2-1 (Test Ad, Operating Cold), IEC 60068-2-2 (Test Bd, Operating Dry Heat), IEC 60068-2-14 (Test Nb, Operating Thermal Shock)	-25...70 °C (-13...158 °F)
Temperature, storage IEC 60068-2-1 (Test Ab, Unpackaged Nonoperating Cold), IEC 60068-2-2 (Test Bb, Unpackaged Nonoperating Dry Heat), IEC 60068-2-14 (Test Na, Unpackaged Nonoperating Thermal Shock)	-40...85 °C (-40...185 °F)
Relative humidity IEC 60068-2-30 (Test Db, Unpackaged Nonoperating Damp Heat)	5...95% noncondensing
Vibration IEC 60068-2-6 (Test Fc, Operating)	2 g at 10...500 Hz
Shock, operating IEC 60068-2-27 (Test Ea, Unpackaged Shock)	30 g
Shock, nonoperating IEC 60068-2-27 (Test Ea, Unpackaged Shock)	50 g

### Technical Specifications - 1756 ControlLogix-XT Chassis

Attribute	1756-A5XT	1756-A7LXT
Backplane current, chassis/slot max @ 1.2V DC	1.5 A/1.5 A	
Backplane current, chassis/slot max @ 3.3V DC	4 A/4 A	
Backplane current, chassis/slot max @ 5.1V DC	15 A/6 A	
Backplane current, chassis/slot max @ 24V DC	2.8 A/2.8 A	
Power dissipation	17 BTU/hr	
Power consumption	5 W	
Slots	5	7
Mounting method	Horizontal only	
Dimensions (WxHxD), approx. <sup>(1)</sup>	158 x 483 x 145 mm (6.22 x 19 x 5.71 in.)	158 x 368 x 145 mm (6.22 x 14.49 x 5.71 in.)
Cabinet size (WxHxD), min	507 x 507 x 203 mm (20 x 20 x 8 in.)	507 x 609 x 203 mm (20 x 24 x 8 in.)
Weight, approx.	1.45 kg (3.2 lb)	1.1 kg (2.4 lb)
Location	Panel	
Enclosure type rating	None (open-style)	

<sup>(1)</sup> Dimensions include mounting tabs and power supply. Depth with extended terminal housing (1756-TBE) is 160 mm (6.3 in.).

## Certifications - ControlLogix-XT Chassis

Certification <sup>(1)</sup>	1756-A5XT, 1756-A7LXT
c-UL-us	UL Listed Industrial Control Equipment, certified for US and Canada. See UL File E65584.  UL Listed for Class I, Division 2 Group A,B,C,D Hazardous Locations, certified for U.S. and Canada. See UL File E194810.
ATEX	European Union 94/9/EC ATEX Directive, compliant with: EN 60079-15; Potentially Explosive Atmospheres, Protection "n" (Zone 2)
CE	European Union 2004/108/EC EMC Directive, compliant with: <ul style="list-style-type: none"> <li>EN 61000-6-4; Industrial Emissions</li> <li>EN 61326-1; Meas./Control/Lab., Industrial Requirements</li> <li>EN 61000-6-2; Industrial Immunity</li> <li>EN 61131-2; Programmable Controllers (Clause 8, Zone A &amp; B)</li> </ul>
C-Tick	Australian Radiocommunications Act, compliant with: AS/NZS CISPR 11; Industrial Emissions

<sup>(1)</sup> When marked. See the Product Certification link at <http://www.ab.com> for Declarations of Conformity, Certificates, and other certification details.

## 1756 Chassis Accessories

Use a slot filler module to fill empty slots.

Cat. No.	Description
1756-N2	Slot filler module for empty slots in standard ControlLogix chassis
1756-N2XT	Slot filler module for empty slots in ControlLogix-XT chassis

## Spacing Requirements

When you mount a chassis with a standard power supply in an enclosure, meet these spacing requirements.

### Enclosure

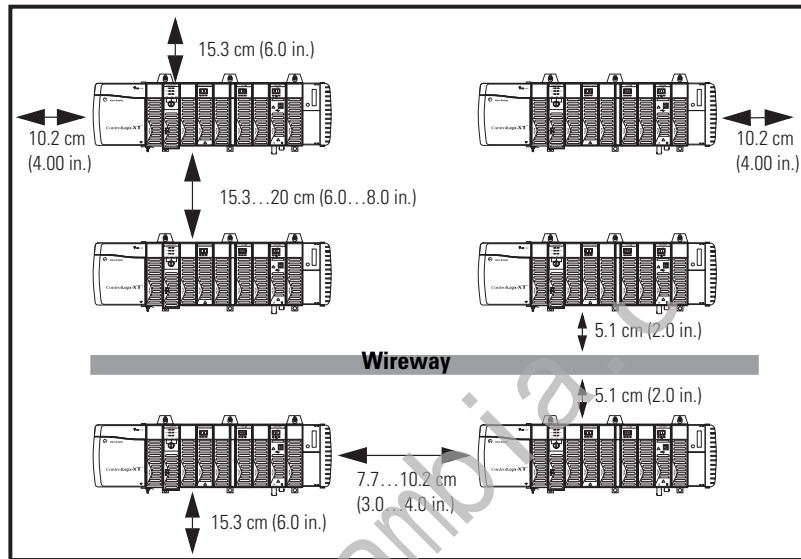

If you use a 1756-PSCA2 chassis adapter with a redundant power supply, follow the same spacing requirements as for a standard power supply. You need the clearance on the left of the chassis for cable access.

### Enclosure

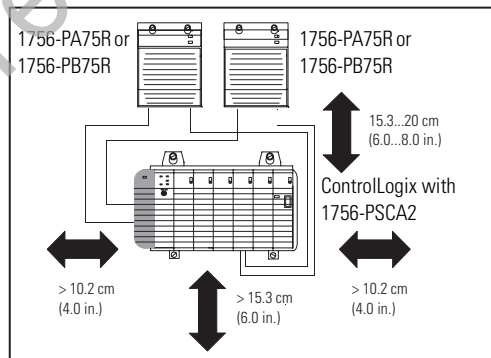

## Standard Mounting Dimensions

### Right-side View of Standard Chassis

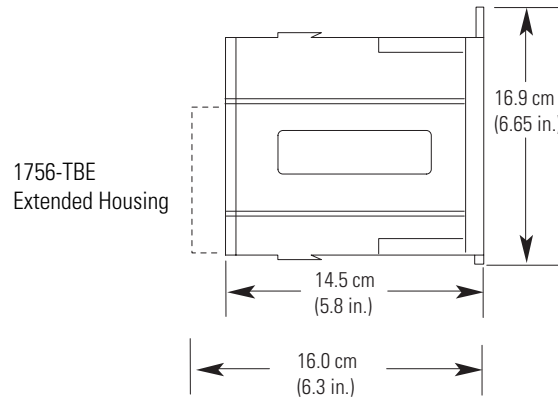

### 1756-A4 with Power Supply

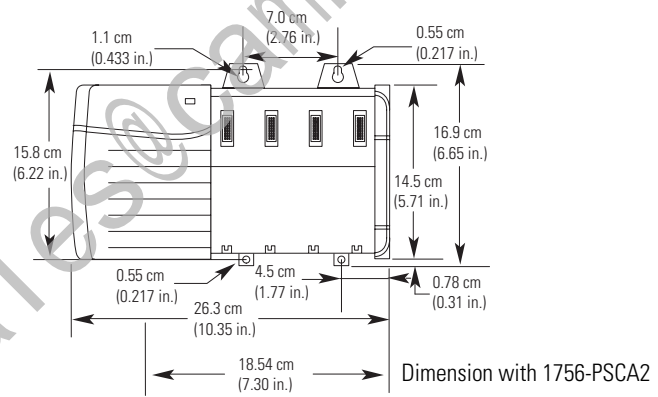



### 1756-A7 with Power Supply

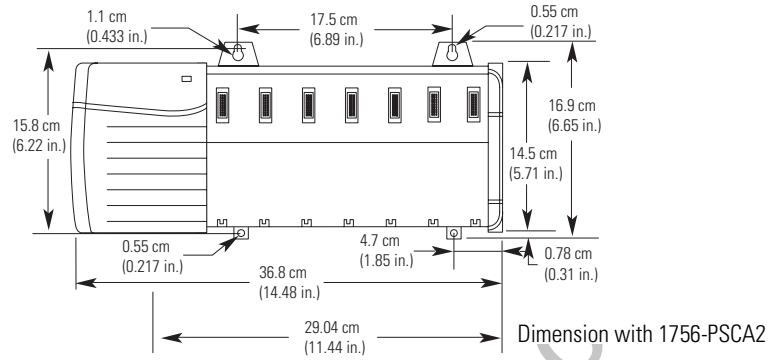

### 1756-A10 with Power Supply

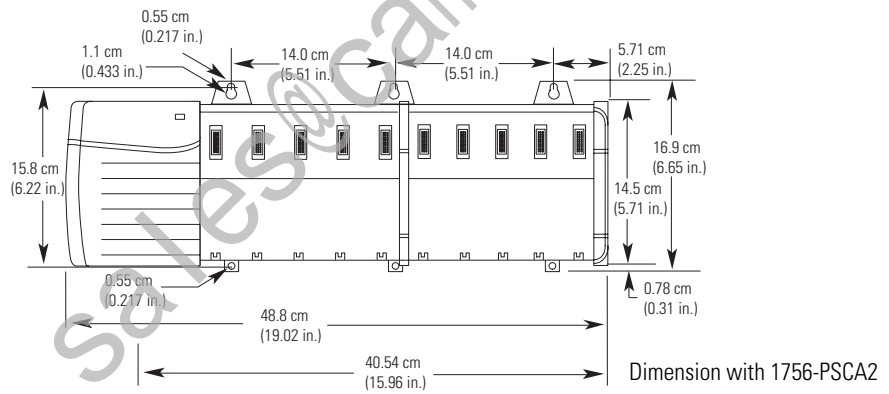

### 1756-A13 with Power Supply

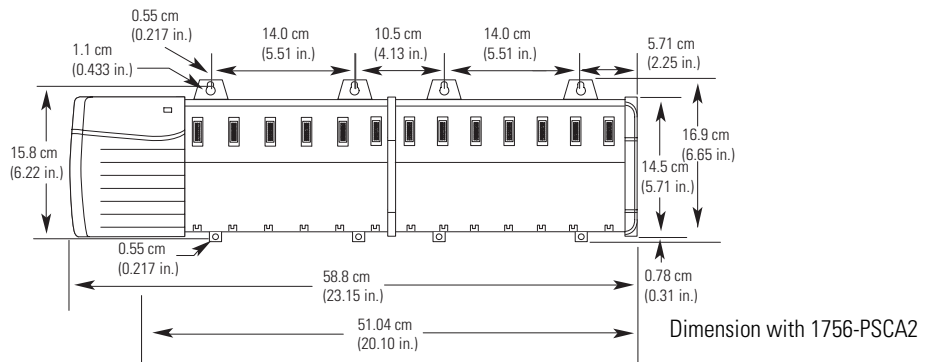

### 1756-A17 with Power Supply

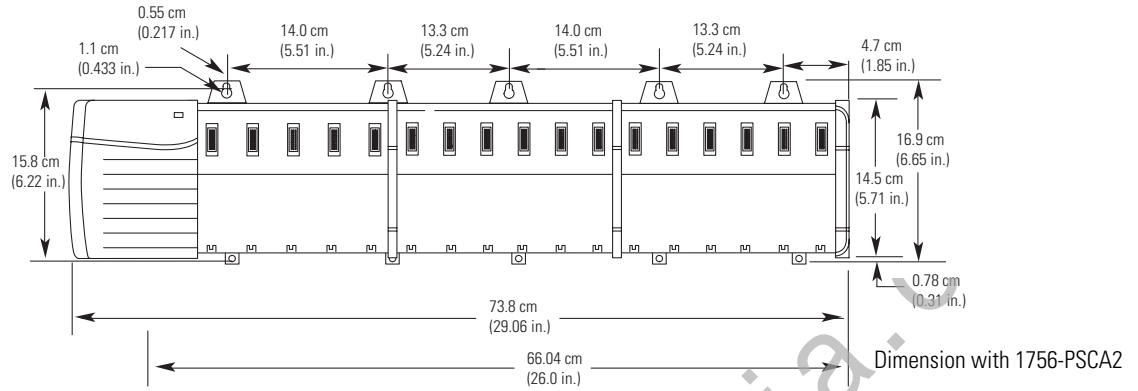

### XT Mounting Dimensions

### Right-side View of XT Chassis

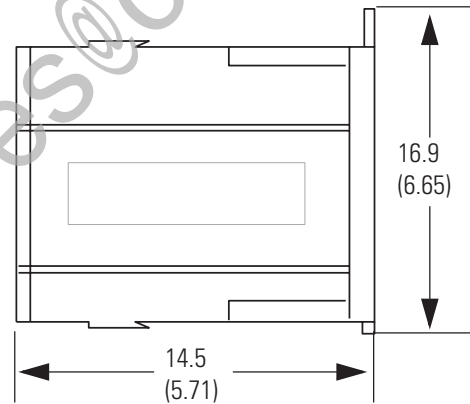

### 1756-A5XT with Power Supply

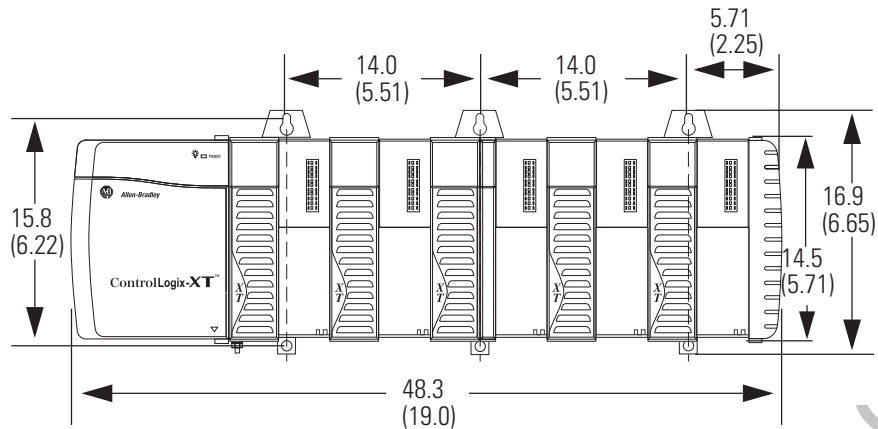

### 1756-A7LXT with Power Supply

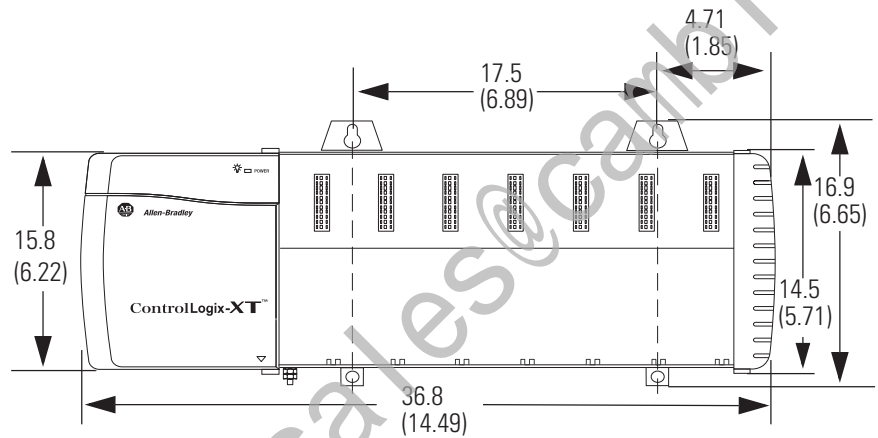

### XT Mounting Tab Dimensions

